

# LED INDICATOR

## Introduction

The LED unit is used to visually indicate the status of the Roboguard system to a distant user. The idea is that the property owner can see whether the alarm has been triggered in their absence and can therefore proceed with caution if this is the case.

+12V, GND (0V), I/O2 and NC (LED-OUT) Pin-outs are clearly indicated on the unit.

**The 2-way dip switch, the I/O1 terminal and RXO DATA are not used in the LED unit.**

The I/O2 terminal is used to connect to the siren trigger connection (yellow HQ wire) via an external Diode-Capacitor filter as shown in the wiring diagram. The Diode-Capacitor filter is essential if the HQ is connected to a siren.

**If no siren is connected, the yellow wire from the HQ can be connected directly to I/O2 and the Capacitor-Diode filter left out.**

The unit has 3 internal LEDs: the first one is not used, a solid middle one displays that the processor is running, and the bottom one shows the LED output (NC) status.

When the LED unit is powered up the bottom indicator will flash. This is the default state of the unit. This will also alert the user of a possible power failure while they were away.

## Installation

Position the LED UNIT in a position suitable for the control of the LED array (separately purchased) and the sampling of the siren control line (YELLOW wire) from the HQ. It might be best to mount the unit close to the HQ and connect the tele-cable directly to the LED unit.

## Wiring

Wire the LED unit to +12V and GND (0V), ensuring the 0V is common with the 0V of the HQ tele-cable (BLUE wire).

Connect the yellow wire from the HQ tele-cable to the free end of the diode (I/O2 terminal).

**Please note:** There are no power connections available from the HQ. The 12 V power supply has to be supplied separately and is usually the same one powering the siren.

Connect the siren and LED array. If a single 3mm or 5mm LED is used it is essential to connect a resistor in-line, as shown.

Resistor values are typically 330 $\Omega$  for high-brights and 1k $\Omega$  for standard ones.

Commercial LED arrays should have protection resistors already fitted or should come with instructions on what is needed.

## Configuration

There are no configurable options in this unit.

## Testing

The installation must be tested for compatibility with the siren as the siren control line is very noisy and may require additional filtering.

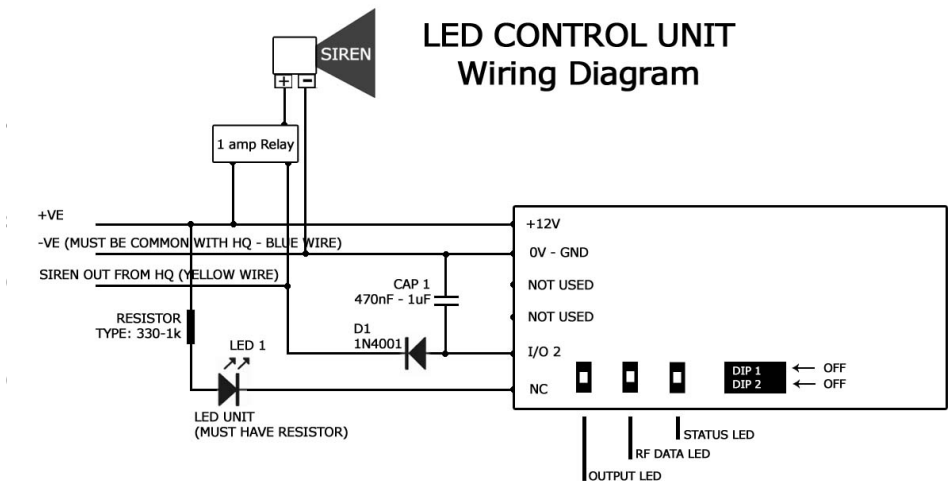

**Wiring the board as packaged:** Connect GND (0V) to Blue wire from HQ, -VE on power supply and -VE on Siren (if used). Connect IO2 via block to HQ yellow (trigger) wire. Connect relay 12V out via block to Siren +VE (if used). Connect your LED between +12 V with resistor and NC. Connect +12V to power supply; The LED will flash until the HQ has been armed by remote, and thereafter operate normally.